

LENNRO mini

Tap water
Reverse Osmosis
systems for small flow

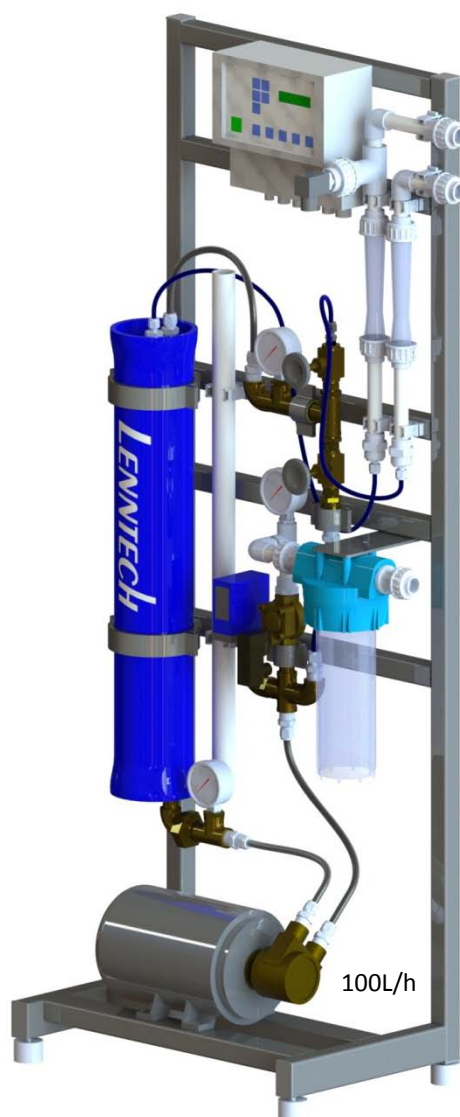

100 L/h
&
200 L/h

Description

Lenntech Mini Reverse Osmosis Systems provide low conductivity water from tap water*. Lenntech units are ready-to-use, skid mounted and easy to operate.

- Compact design, low energy demand and high recovery;
- Fully automatic system, microprocessor controlled.

This system includes

- 5-micron cartridge filter;
- High pressure pump, brass pump head;
- Permeate conductivity indicated in the front panel display;
- High performance Dow membranes;
- Fiberglass pressure vessels;
- Permeate and concentrate flow meters;
- Pressure indicators: feed pressure, high pressure and concentrate pressure;
- Low pressure switch before the HPP;
- Controller for fully automatic operation;
- PVC piping, flexible braided hose, PE hose;
- Needle valves, inlet valve, high pressure pump and appendages in brass.

Options

- Softener as a pre-treatment for high hardness water

Feed water quality specifications

Parameter	Range
Total dissolved solids	Max. 500 ppm
pH value continuously	2-11
pH short time during cleaning	1-12
Dissolved iron	Max 0.05 ppm
Dissolved manganese	Max 0.05 ppm
Chlorine (continuously)	0 ppm
Oil and grease	0 ppm
Silt Density Index SDI ₁₅	< 3
Turbidity	< 1 NTU
Temperature	Min. 15°C - max. 25°C
Pre-pressure	Min. 2 bar - max. 4 bar

Technical data**

Lenntech mini	100	200
Permeate flow L/h	100	200
Feed flow L/h	135	270
Recirculation flow L/h	665	530
Recovery	75%	75%
Permeate TDS ppm	< 50	< 50
Membranes	1x XLE 4021	1x XLE 4040
Array (# Vessels)	1	1
Pump power	0,55 kW	0,55 kW

**) Water quality resembling tap water quality (low brackish water) can also be used as feed water, consult a Lenntech engineer with the water analysis of your feed water source*

****) These data are given for information purpose only. They are subject to modifications depending on the water quality.*

Dimensions

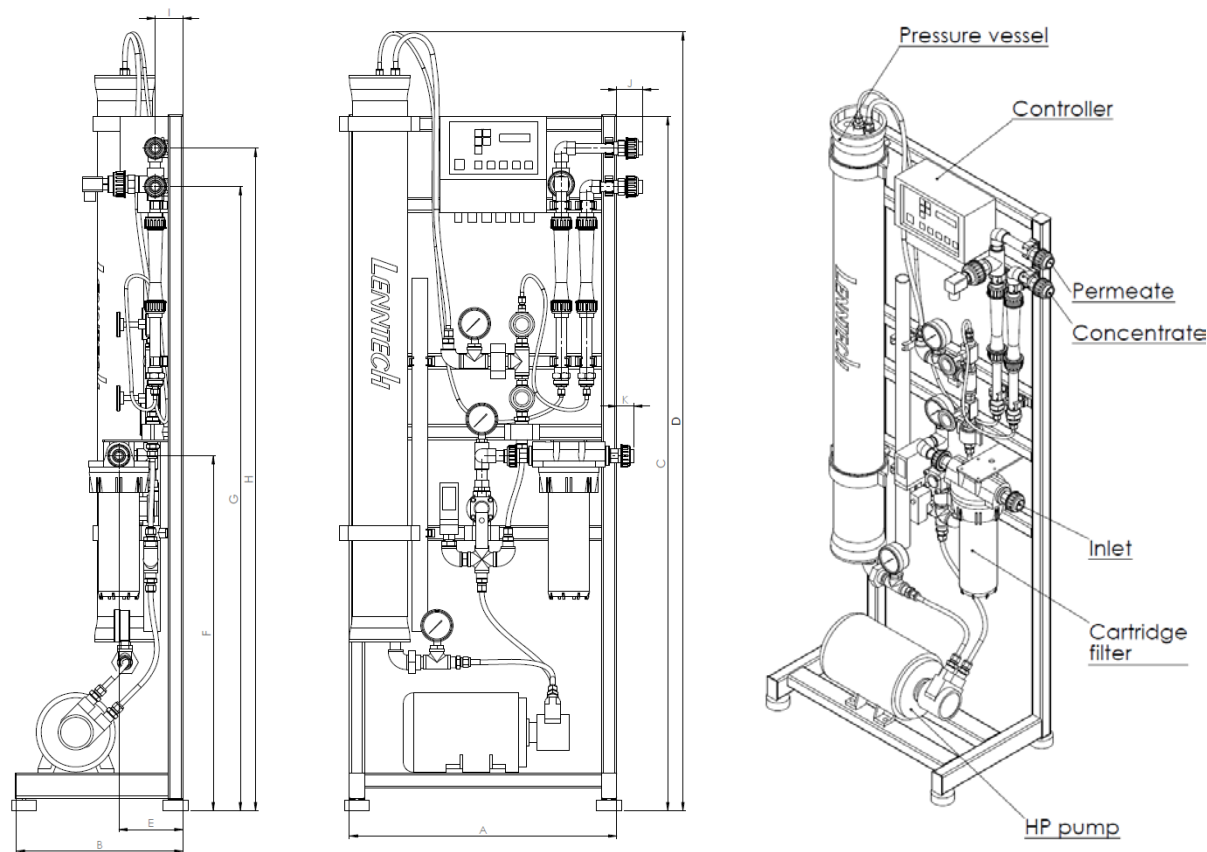

Dimensions (mm)	100	200
A	530	530
B	330	330
C	1375	1375
D	1375	1550
E	127	127
F	703	703
G	1236	1236
H	1312	1312
I	55	55
J	51	51

Connections (mm)	100	200
Feed	DN15	DN15
Permeate	DN15	DN15
Concentrate	DN15	DN15
CIP connections	N/A	N/A
Skid Weight (Kg)	100	200
Full	60kg	65kg

Reverse Osmosis units often required pre-treatment for the following parameters:

- Suspended solids
- TOC, COD/BOD, oil and grease
- Iron and manganese
- Hardness removal/ reduction

Lenntech provides all kinds of pre and post treatment required before and after your RO, according to your water analysis and process requirements. Please contact us for further information.